

DMX-SPI-200 DMX-SPI Decoder



DMX-SPI-200 is DMX-SPI signal decoder, which convert the DMX512 digital signal into SPI(TTL) digital signal. It can work on the DMX console to control the LED lights with compatible driving ICs. DMX console can control every channel of the LED lights, outputting 256 grey scales per channel, realizing 0-100% dimming and various changing effect.

DMX-SPI-200 can switch 7 kinds of IC type, support more different lamps types of IC driver.

Besides DMX decoding function, it can be used as SPI console, has 35 kinds of built-in lighting effects.

1. Technical Specs

DMX-SPI-200	
Input signal	DMX512
Input voltage	DC5V~DC24V
Decoder channels	512 DMX CH/unit
Gray scale level	256 levels/CH (8bit/CH)
Compatible IC	TM1804, TM1809, TM1812, UCS1903, UCS1909, UCS1912, UCS2903, UCS2909, UCS2912, TM1803, TLS3001, TLS3002, LPD6803, LPD1101, D705, UCS6909, UCS6912, LPD8803, LPD8806, WS2801, WS2803, WS2811, WS2812, P9813
Dimming range	0~100%
Working temperature	-30°C~65°C
Dimension	L175×W42×H33mm
Package Size	L178×W46×H58mm
Weight (G.W)	310g

2. Construction Drawing

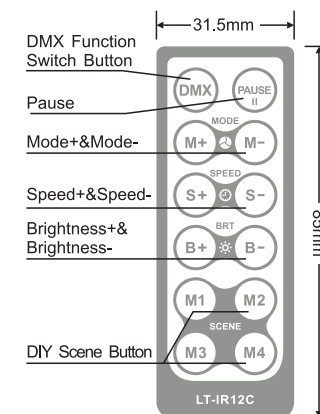
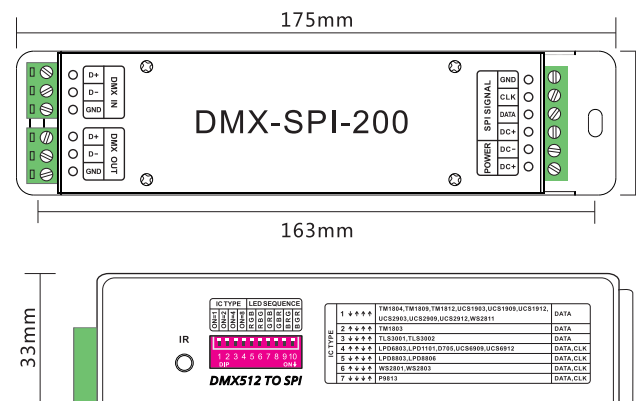

IR Remote Control

Other functions of remote-control buttons:

1. DMX: long press to turn off, press any key or change the Dip Switch to continue
2. PAUSE: long press to switch dynamic changing mode direction, "forward" or "reverse"
3. MODE+: DMX decoder mode revert to changing mode; long press to dynamic change mode Cycle
4. MODE-: DMX decoder mode revert to changing mode, long press to DIY dynamic change mode Cycle
5. SPEED+: 8 steps speed changing, the current changing speed revert to the fastest in long pressing.
6. SPEED-: 8 steps speed changing, the current changing speed revert to the Slowest in long pressing.
7. M1-M4: 4 DIY keys, 4 DIY changing effect, defaults to 7 color skipping, 7 color smooth, 7 color chasing, 7 color float. Scene modes recall the pattern, speed and brightness values of the changing effects.

3. Selection for IC types and RGB Sequence

1. Through the top 4 dip switches to select the IC types. Default 1# IC types when 4 dip switches are OFF

No.	4 dip switch selection	IC types	Output signal
1		TM1804, TM1809, TM1812, UCS1903, UCS1909, UCS1912, UCS2903, UCS2909, UCS2912, WS2811	DATA
2		TM1803	DATA
3		TLS3001, TLS3002	DATA
4		LPD6803, LPD1101, D705, UCS6909, UCS6912	DATA, CLK
5		LPD8803, LPD8806	DATA, CLK
6		WS2801, WS2803	DATA, CLK
7		P9813	DATA, CLK

2. 6 kinds of RGB sequence through after 6 dip switches to select, dip "ON" means current LED sequence. If multi-dip switches are ON, default the minimum dial-up is effective.

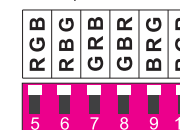

4. Tables of Changing Modes

No.	Color	No.	Color
1	static red	19	7 color I chasing (each color 8 pixels)
2	static green	20	White meteor I (each color 16 pixels fade out, interval 16 pixels of black)
3	static blue	21	RGB meteor (each color 16 pixels fade out, interval 16 pixels of black)
4	static yellow	22	7 color meteor(each color 16 pixels fade out, interval 16 pixels of black)
5	static purple	23	Red and white float
6	static cyan	24	Green and white float
7	static white	25	Blue and white float
8	RGB skipping	26	Red and yellow float
9	7 color skipping	27	Red and purple float
10	RGB strobe	28	Green and yellow float
11	7 color strobe	29	Green and cyan float
12	RGB smooth	30	Blue and purple float
13	7 color smooth	31	Blue and cyan float
14	RGB fade out & fade in	32	Red, yellow and green float
15	7 color fade out & fade in	33	Red, purple and blue float
16	RGB Flow (front color as the background)	34	Green, cyan and blue float
17	7 color Flow (front color as the background)	35	7 color float
18	RGB chasing (each color 8 pixels)		

5. Conjunction diagram

1. DMX decoding mode

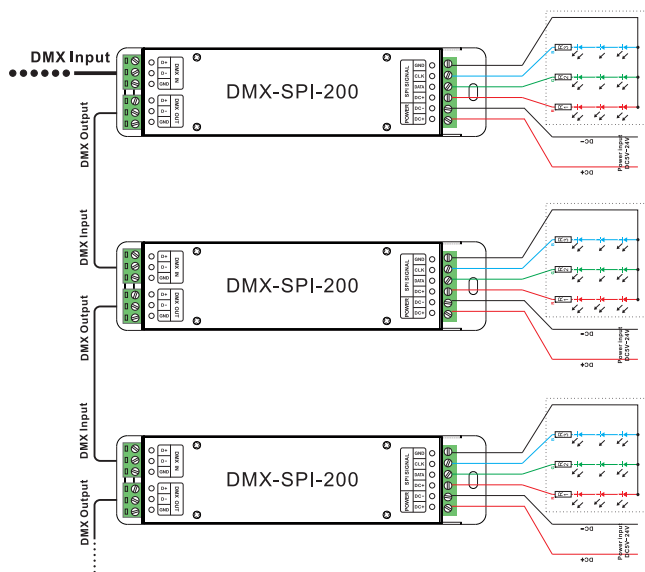

2. SPI mode

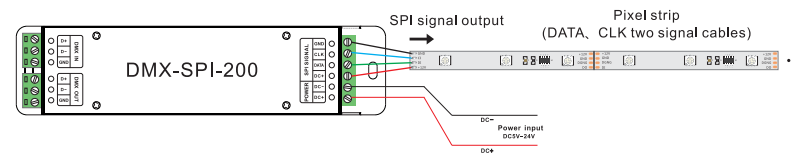

5. Attention

- The product shall be installed and serviced by a qualified person.
- This product is non-waterproof. Please avoid the sun and rain. When installed outdoors please ensure it is mounted in a water proof enclosure.
- Good heat dissipation will prolong the working life of the controller. Please ensure good ventilation.
- Please check if the output voltage of any LED power supplies used comply with the working voltage of the product.
- Please ensure that adequate sized cable is used from the controller to the LED lights to carry the current. Please also ensure that the cable is secured tightly in the connector to avoid the accidents due to overheat and poor contact on the wire.
- Ensure all wire connections and polarities are correct before applying power to avoid any damages to the LED lights.
- If a fault occurs please return the product to your supplier. Do not attempt to fix this product by yourself.

6. Warranty Agreement

- We provide lifelong technical assistance with this product:
 - A 5-year warranty is given from the date of purchase. The warranty is for free repair or replacement and covers manufacturing faults only.
 - For faults beyond the 5-year warranty we reserve the right to charge for time and parts.
- Warranty exclusions below:
 - Any man-made damages caused from improper operation, or connecting to excess voltage and overloading.
 - The product appears to have excessive physical damage.
 - Damage due to natural disasters and force majeure.
 - Warranty label, fragile label and unique barcode label have been damaged.
 - The product has been replaced by a brand new product.
- Repair or replacement as provided under this warranty is the exclusive remedy to the customer. Ltech shall not be liable for any incidental or consequential damages for breach of any stipulation in this warranty.
- Any amendment or adjustment to this warranty must be approved in writing by Ltech only.

★ This manual only applies to this model. Ltech reserves the right to make changes without prior notice.